

Uniform, Semi-Automatic Carton Forming and Filling Station

STA-PP50

S E R I E S

- Simple, easy set-up
- Engineered for 24 hour operation
- All pneumatic, no electric
- Guide system for easy loading
- Pneumatic ram discharge system to eject box into taping machine
- Wide box range
- Change over quickly from one box size to another
- Integrates with sealing machine



APPLICATION

The STA-PP50 Series is a carton forming machine that automatically prepares the boxes with the four bottom flaps folded in position. In seconds, the carton is ready for the operator to fill, allowing use of both hands for placing the product into the carton. After the carton is filled, the operator presses a button and the STA-PP50 Series automatically transfers the carton into a uniform case sealer for top and bottom sealing.

For larger cartons, the STA-PP65 model performs the same process. Additionally, the STA-PP50 Series can be linked with carton sealing machines by motorized conveyors.

EXCLUSIVE STA TAPE HEAD

Optional packaging modules with taping devices are available as add-ons to the STA-PP50 packing station. The patented STA taping head design is uniquely engineered to maintain consistent pressure to the tape to ensure the most secure, reliable seal possible. Our new line of interchangeable pressure sensitive taping heads is offered in a variety of tab lengths and tape widths to fit your application.

For the best results, rely on STA Proven Performance acrylic tapes, for use with your high-throughput sealing machines. Together, you have the most reliable single source tape sealing system.



STA-PP50

S E R I E S

Uniform, Semi-Automatic Carton Forming and Filling Station

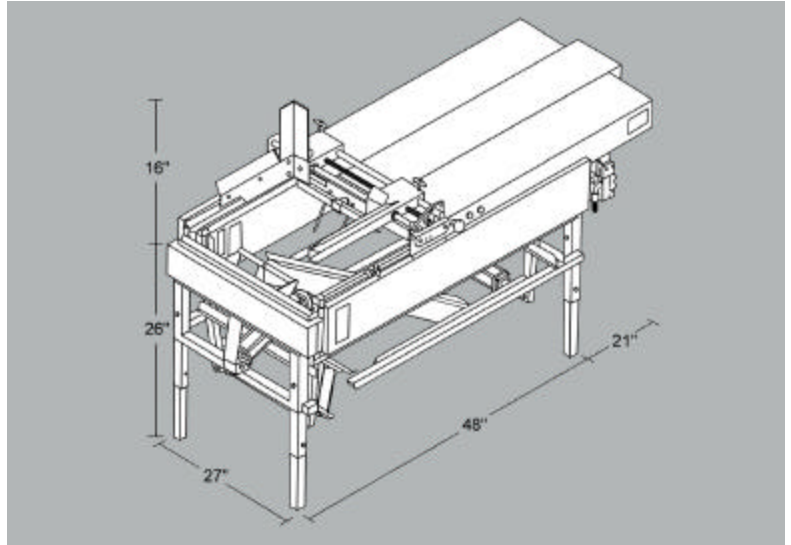

TAPE

- SUPREME
- EASY RELEASE™
- NATURAL RUBBER
- PRINTED
- COLORS
- RETAIL ROLL
- LABEL PROTECTION
- STATIONERY
- UPVC
- MASKING
- STRAPPING
- FILAMENT
- WATER ACTIVATED REINFORCED AND GUMMED PAPER

DISPENSERS

- HAND DISPENSERS
- NOISE REDUCING DISPENSERS
- BENCH DISPENSERS

MACHINES

- UNIFORM SEMI-AUTOMATIC CASE SEALERS
- UNIFORM AUTOMATIC CASE SEALERS
- RANDOM SEMI-AUTOMATIC CASE SEALERS
- RANDOM AUTOMATIC CASE SEALERS
- PACKING STATIONS
- CASE ERECTORS
- INTERCHANGEABLE TAPE HEADS

ACCESSORIES

- PACKING TABLES & STATIONS
- CASTERS
- THREE FLAPS CLOSERS
- BOX BLOCKING SYSTEM

SPECIFICATIONS

Model Number	Description	Length Min.-Max.*	Width Min.-Max.*	Height Min.-Max.*
STAPP50	Pack Point	7.87 - 25.59	5.91 - 19.26	4.72 - 19.96
STAPP65	Pack Point	11.81 - 29.53	7.87 - 24.80	4.72 - 23.62

*Recommended carton specifications may vary

Maximum Case Weight:	95 lbs.
Air Requirements:	PSI: 80-100 lbs., CFM: 5+, dry air, 3/8" supply line
Machine Dimensions:	PP50: (LxWxH) 48-69" x 27" x 42", PP65: (LxWxH) 52-74" x 33" x 42"
Shipping Dimensions:	PP50: (LxWxH) 51" x 30" x 32", PP65: (LxWxH) 57" x 36" x 39"
Machine Weight:	PP50: 216 lbs., PP65: 249 lbs.
Shipping Weight:	PP50: 1,032 lbs., PP65: 352 lbs.

Authorized STA Packaging Tapes Distributor:

Specifications are subject to change without notice. Printed in the U.S.A. All trademarks and registered trademarks are property of Sekisui TA Industries, Inc.

SEKISUI TA INDUSTRIES, INC. • 100 SOUTH PUENTE STREET • BREA, CA 92821
(800) 258-8273 / (714) 255-7888 PHONE • (800) 235-8273 FAX • www.sta-tape.com