

Complete Packaging and Case Sealing System

STA-52 Line

S E R I E S

- Carton packing station
- Cost effective uniform carton sealer
- 2" or 3" Taping
- Top mast can be raised to accommodate taller cartons
- Can use 3 flaps closer and other options
- Casters are standard
- Fast, easy setup and adjustments
- Motor overload protection
- Includes infeed and exit conveyors with casters
- Heavy duty frame
- Heavy duty transmission system



APPLICATION

The STA-52 Line is a complete modular designed packaging and sealing system for runs of uniform size cartons, including high-efficiency infeed conveyor with a box hold down feature and exit conveyor. The empty carton is held in place for filling on the box packing station. After filling, the operator closes the top flaps and feeds the carton into the machine for top and bottom taping. There is no limit on the length and the machine can handle a maximum width of 20.47" and a maximum height of 23.50". Its versatility rates as one of the best in the market.

Dual side belt drives make the STA-52 Line well suited for a wide range of carton sizes and shapes. Along with the 90 FPM belt speed, it's one of the most cost effective case sealers in the industry.

EXCLUSIVE STA TAPE HEAD

The patented STA taping head design is uniquely engineered to maintain consistent pressure to the tape to ensure the most secure, reliable seal possible. Our new line of interchangeable pressure sensitive taping heads are offered in a variety of tab lengths and tape widths to fit your application.

For the best results, rely on STA Proven Performance acrylic tapes, for use with your high-throughput sealing machines. Together, you have the most reliable single source tape sealing system.

STA-52 Line

S E R I E S

Complete Packaging and
Case Sealing System

TAPE

- SUPREME
- SILENT SUPREME™
- EASY RELEASE™
- NATURAL RUBBER
- PRINTED
- COLORS
- RETAIL ROLL
- LABEL PROTECTION
- STATIONERY
- UPVC
- MASKING
- STRAPPING
- FILAMENT
- WATER ACTIVATED REINFORCED AND GUMMED PAPER

DISPENSERS

- HAND DISPENSERS
- NOISE REDUCING DISPENSERS
- BENCH DISPENSERS

MACHINES

- UNIFORM SEMI-AUTOMATIC CASE SEALERS
- UNIFORM AUTOMATIC CASE SEALERS
- RANDOM SEMI-AUTOMATIC CASE SEALERS
- RANDOM AUTOMATIC CASE SEALERS
- PACKING STATIONS
- CASE ERECTORS
- INTERCHANGEABLE TAPE HEADS

ACCESSORIES

- PACKING TABLES & STATIONS
- CASTERS
- THREE FLAPS CLOSERS
- BOX BLOCKING SYSTEM

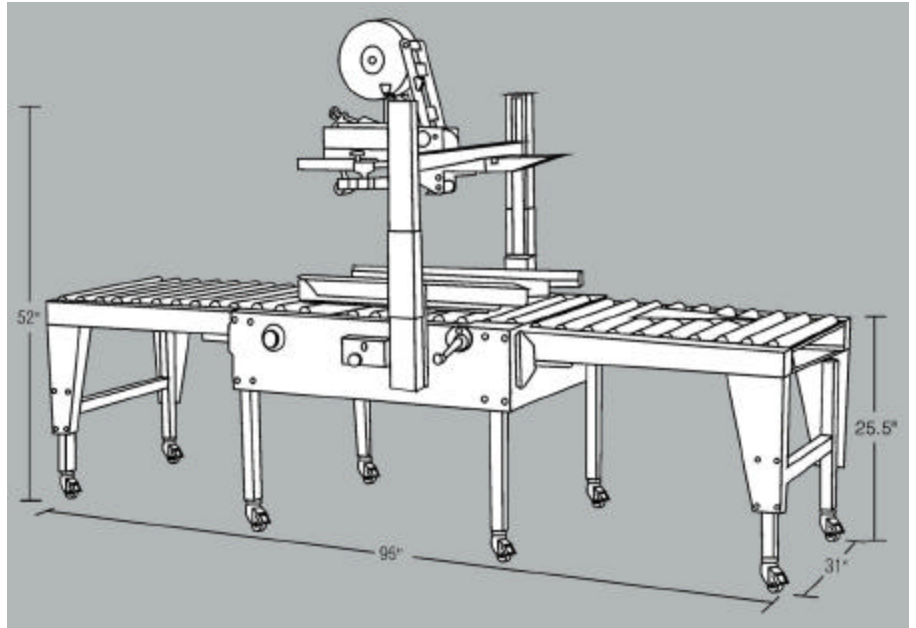

SPECIFICATIONS

| Model Number | Tape Width | Tab Length | Length Min.-Max.* | Width Min.-Max.* | Height Min.-Max.* |
|--------------|------------|------------|-------------------|------------------|-------------------|
| STA52LINE | 2" | 2" | 5.90-Unlimited | 3.94-20.47 | 3.94-19.68 (+4) |
| STA52LINE21 | 2" | 1" | 5.90-Unlimited | 3.94-20.47 | 3.94-19.68 (+4) |
| STA52LINE23 | 2" | 3" | 5.90-Unlimited | 3.94-20.47 | 4.69-19.68 (+4) |
| STA52LINE33 | 3" | 3" | 5.90-Unlimited | 4.94-20.47 | 4.69-19.68 (+4) |
| STA52LINE32 | 3" | 2" | 5.90-Unlimited | 4.94-20.47 | 3.94-19.68 (+4) |

*Recommended carton specifications may vary

Power Requirements: 110V / 60Hz / 1PH

Tape Width: 2-in, 3-in

Maximum Case Weight: 95 lbs.

Belt Speed: 90 FPM

Machine Dimensions: (LxWxH) 95" x 33" x 51"-65"

Shipping Dimensions: (LxWxH) 36" x 35" x 38"

Machine Weight: 225 lbs.

Shipping Weight: 270 lbs.

Authorized STA Packaging Tapes Distributor:

Specifications are subject to change without notice. Printed in the U.S.A. All trademarks and registered trademarks are property of Sekisui TA Industries, Inc.